



- Slip Rings
- Encoders
- Linear Measuring Technology
- Counters and Process Devices

Flexible  
Innovative  
Adding value  
Partnership-based

---

The Kübler Group belongs today to the leading specialists worldwide in the fields of position and motion sensors, functional safety, counting and process technology as well as transmission technology.

The packaging industry is one of our most important core activities offering products, solutions and services that inspire our customers.

We rely on close and personal co-operation to produce solutions with high customer benefit.



## Contents

<b>Added value for our customers</b>	<b>4</b>
<hr/>	
<b>Slip rings</b>	
Modular slip rings SR085	6
The Flow Pack specialist: Slip ring SR060E	8
Ethernet transmission – Slip ring SR120	10
Kübler slip ring technology – long-lasting and maintenance-free	12
<hr/>	
<b>Encoders</b>	
Kübler encoder solutions	14
Encoder technologies for the packaging industry	18
<hr/>	
<b>Linear measuring systems</b>	<b>20</b>
<hr/>	
<b>Counters and process devices</b>	<b>22</b>
<hr/>	
<b>Kübler Services</b>	
Tailor-made solutions – Kübler Design System	24
Kübler Service for Planning Dependability	25

Added value for our customers

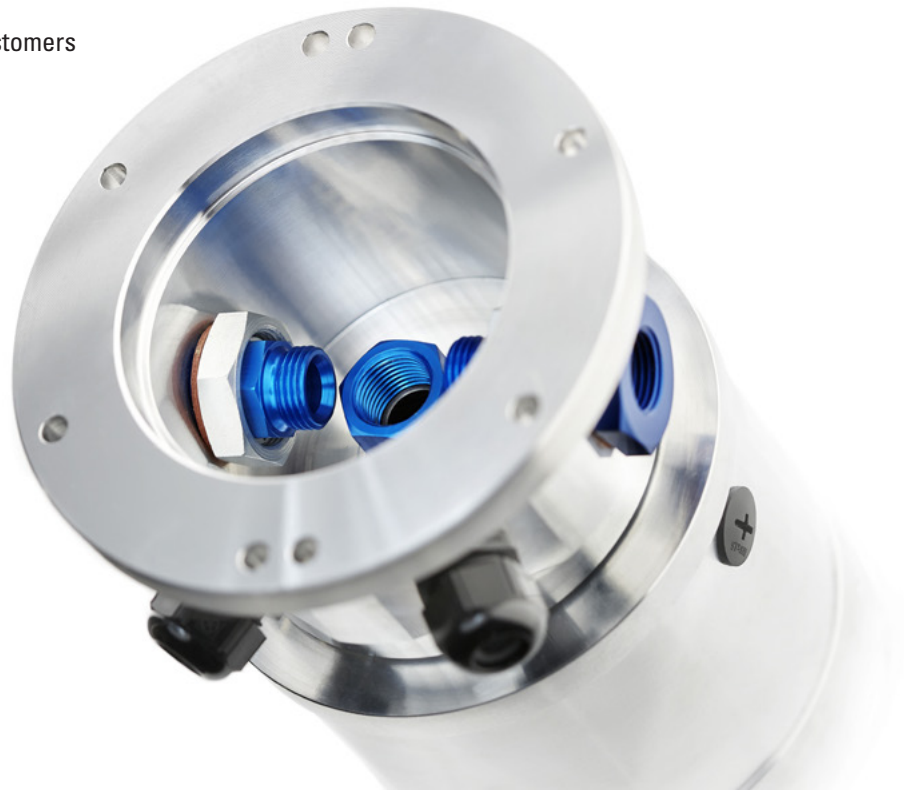

## Flexibility and quality

A wide product range characterized by high quality standards allows us to meet a variety of very different customer requirements. In addition, our constant goal is to reduce system costs and to create added value thanks to innovations.

## Innovation and partnership

For us, innovation comes from creativity that allows us thinking out of the box. We develop, jointly with our customers, novel products, solutions and services. Thanks to the close proximity to our customers, we make sure that our innovations meet all their requirements.



Headquarters in Villingen-Schwenningen





## Customer-specific development

Standardizing and modularization are of essential importance in the packaging industry. Nevertheless, special solutions are still an important element in many companies to allow them realizing customer-specific applications. Kübler has been proving for many years its ability to respond flexibly to special solutions, especially in the packaging technology, where optimal connection of the slip ring to the application is imperative.

In short: we want to supply the ideal slip ring for your packaging machine.

## Kübler Group – 55 years of innovation

Founded in the year 1960 by Fritz Kübler, the family business is now led by the next generation of the family, his sons Gebhard and Lothar Kübler. Ten international group members and distributors in more than 50 countries offer local product know-how, service and advice throughout the world. Innovative product and sector solutions, as well as solutions for functional safety and a high level of service, are the reasons behind our global success. The strict focus on quality ensures the highest levels of reliability and a long service life for our products in the field. Over 480 dedicated people worldwide make this success possible and ensure that customers can continue to place their trust in our company.



## Modular slip rings SR085

For the rotary transmission of load, signals and data, pneumatics and hydraulics.

In general slip rings are used to transmit load, signals or data, pneumatic and hydraulic, from a stationary to a rotating platform. The transmission between the stator and rotor takes place via sliding contacts and is extremely reliable. The construction is modular and offers the greatest flexibility in a variety of applications.



### The modular all-rounder: SR085

#### Flexible and rugged

- Modular construction system, load and signal / data channels can be combined as desired
- Rugged GFPC housing (glass-reinforced polycarbonate), 30% glass-fiber content for industrial usage

#### Innovative contact materials

- Long service life and long maintenance cycles
- Easy maintenance – without contact oil
- Fieldbus signals such as Profibus, CANopen etc. up to 12 Mbit/s

#### Reliable thanks to the Safety-Trans™-Design

- Two-chamber system for load and signal / data transmission
- High vibration resistance

#### Characteristics

- Hollow shaft up to  $\varnothing$  30 mm
- Power channels up to 25 A and 400 V AC/DC
- Protection level up to IP64
- Speed up to 800 min<sup>-1</sup>
- Operating temperature -35°C ... +85°C
- Up to 20 transmission paths
- Long maintenance cycles, only every 100 million revolutions



### Multimedia transmission system: SR085

#### Media lead-through with air connection

- For flange assembly up to 800 min<sup>-1</sup>  
1/4", 3/8", 1/2"
- For hollow shaft assembly, rotatable connection up to 300 min<sup>-1</sup>

#### Media lead-through with hydraulic connection

- For flange assembly 3/8", 1/2"



Version with rotatable connector (air)

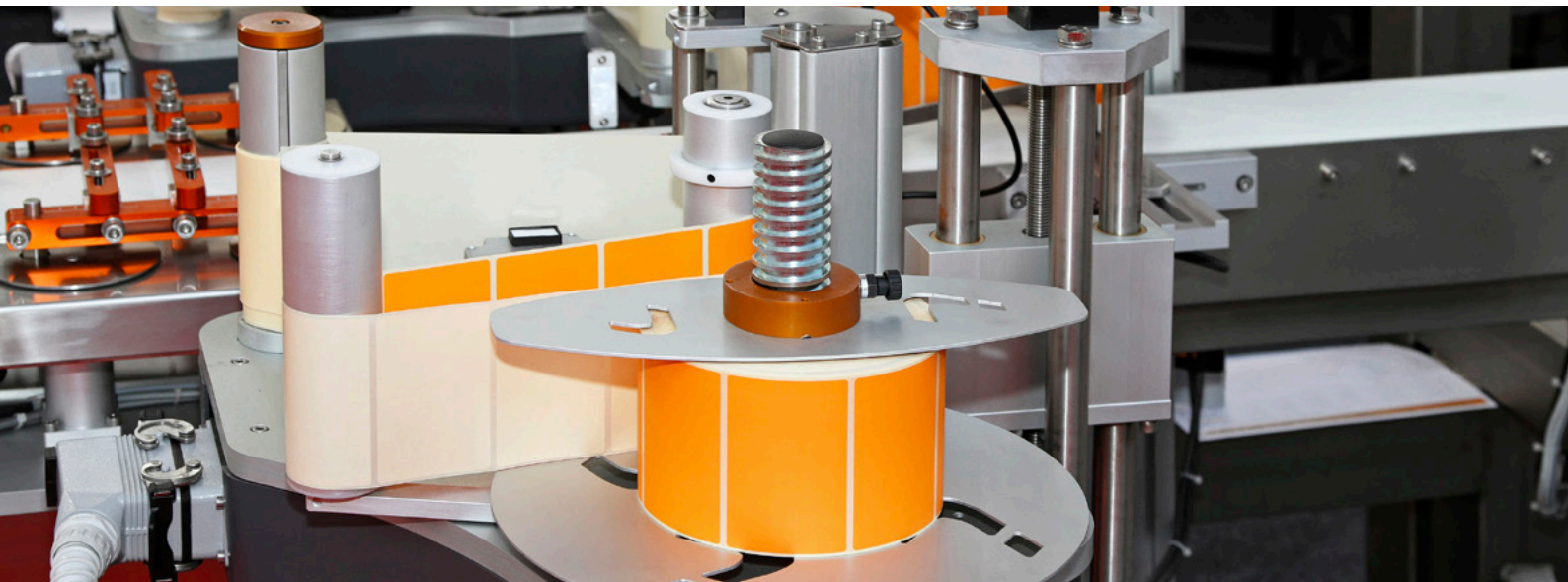

### Non-contact and maintenance-free: SRI085

#### Contactless signal transmission

- Transmission of up to 3 x PT100
- No plant standstill, no abrasion dust, long service life
- Signal / data channels maintenance-free by means of inductive coupling

#### Modular construction system

- Tailored to the application
- Flexible combination of load and signal channels
- Rugged GFPC housing (glass-reinforced polycarbonate), 30% glass-fiber content for industrial usage
- High vibration resistance

#### Characteristics

- Hollow shaft up to  $\varnothing$  30 mm
- Up to 6 load channels, up to 16 A
- Protection level up to IP65
- Speed up to 800 min<sup>-1</sup>
- Operating temperature -30°C ... +85°C

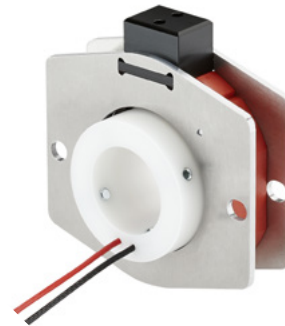

### Flexible and cost-effective: SR085B

#### Flexible and bearingless modular system

- Customer-specific and cost-effective slip ring
- Easy installation in restricted mounting spaces

#### Compact design

- Flat construction and reduced length (from 33 mm installation depth)

#### Innovative contact materials

- Long service life and high reliability

#### Characteristics

- Hollow shaft up to  $\varnothing$  34 mm
- Up to 10 transmission paths
- Protection level up to IP40 – protected against accidental contact, no intrusion of foreign particles
- Speed up to 200 min<sup>-1</sup> – for slowly rotating applications
- Operating temperature 0°C ... +75°C

# The Flow Pack specialist: Slip ring SR060E

The SR060E is a compact, economical slip ring for up to 3 load and 2 signal / data transmissions – ideally suited for the heating of sealing drums (rollers) in packaging machines. The smooth and flat surfaces allow easy cleaning and therefore meet the requirements of the food processing industry. Thanks to innovative contact materials, the slip rings require no more oiling. A particularly long service life is ensured.

## **i** Innovative contact material

- Easy maintenance by simple vacuum cleaning, without contact oil
- Protection level up to IP64 – their smooth and straight surfaces allow easy cleaning and therefore meet the requirements of the food processing industry
- Long maintenance cycles, only every 100 million revolutions
- Long service life, typ. 500 million revolutions – therefore less machine downtime, increased productivity and more reliability

Fully encapsulated in high-grade glass fiber reinforced plastic housing shells (30% glass fiber proportion)

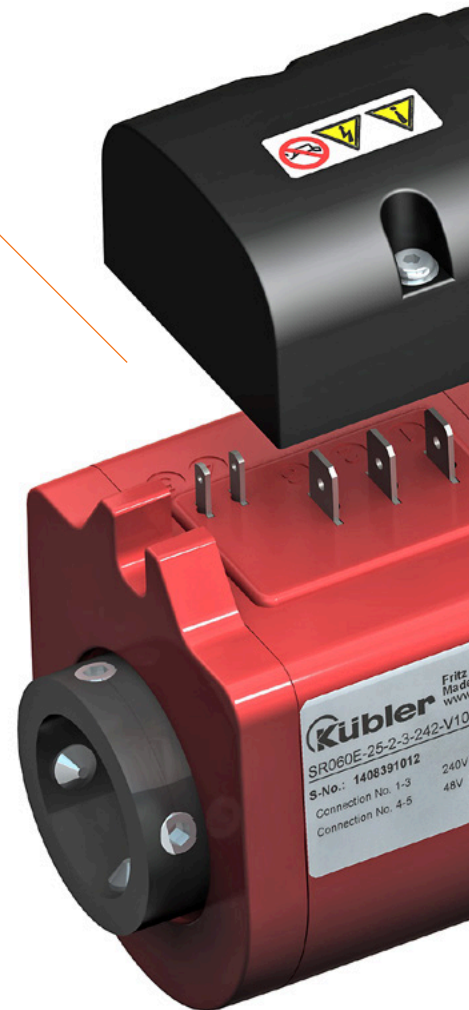

Speed up to 500 min<sup>-1</sup>



High shock and vibration resistance



Hollow shaft up to ø 25 mm



Dimensions 60 x 98 mm  
(can be used as a pair starting from 60 mm sealing rollers axes distance)



Protection level up to IP64, easy cleaning



Operating temperature 0°C ...+75°C

- High load current transmission, up to 20A. Shorter and faster temperature control e.g. of sealing rollers
- IP64 protection level – easy cleaning with a damp cloth or a water jet





## Applications

From the heating and monitoring of the sealing rollers in blister or tubular bag machines (or Flow Pack) to the use in balancing devices and indexing tables.

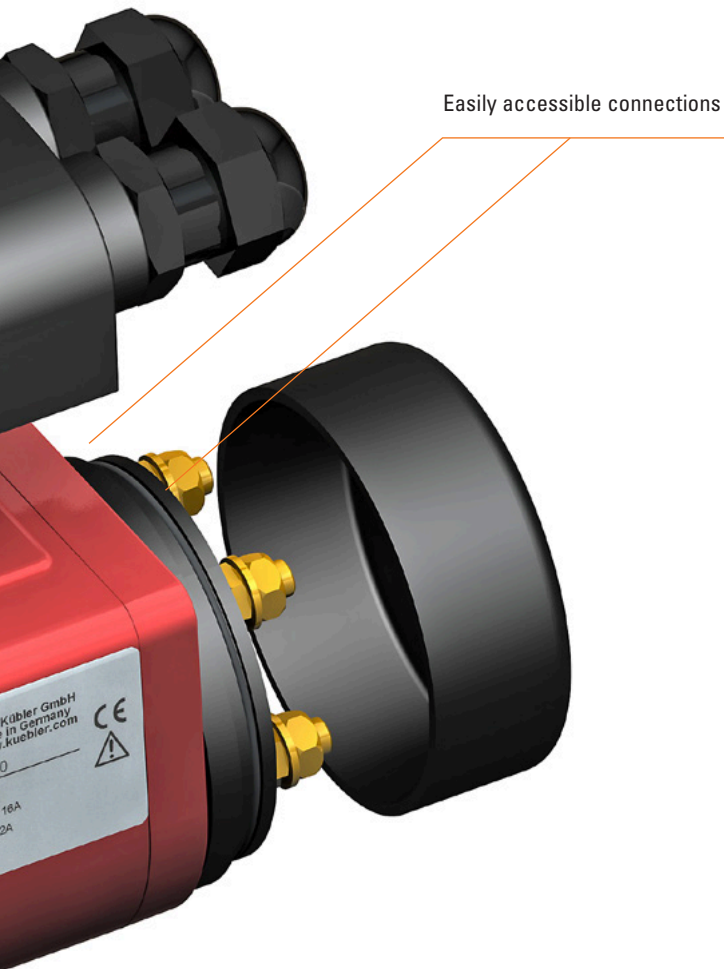

### **i** Two-chamber system: Safety-Trans™ Design

Two-chamber system to separate the load and signal / data transmission.

A labyrinth seal increases the clearance and creepage distance to ensure electrical insulation and protects the signal contacts against contamination with abrasion dust. This extends significantly the service life and the maintenance cycles.

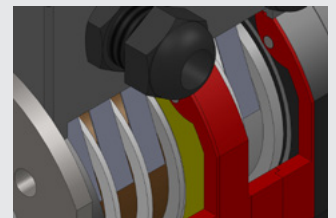

## Ethernet transmission – Slip ring SR120

Three-chamber system. The slip ring SR120 is ideal for applications requiring high transmission rates. The three-chamber system allows parallel transmission of signals, load, data and Ethernet. Various connection possibilities and a robust and modular design ensure flexible and reliable operation. Thanks to its proven contact technology, this slip ring requires very little maintenance and boasts a particularly long service life.

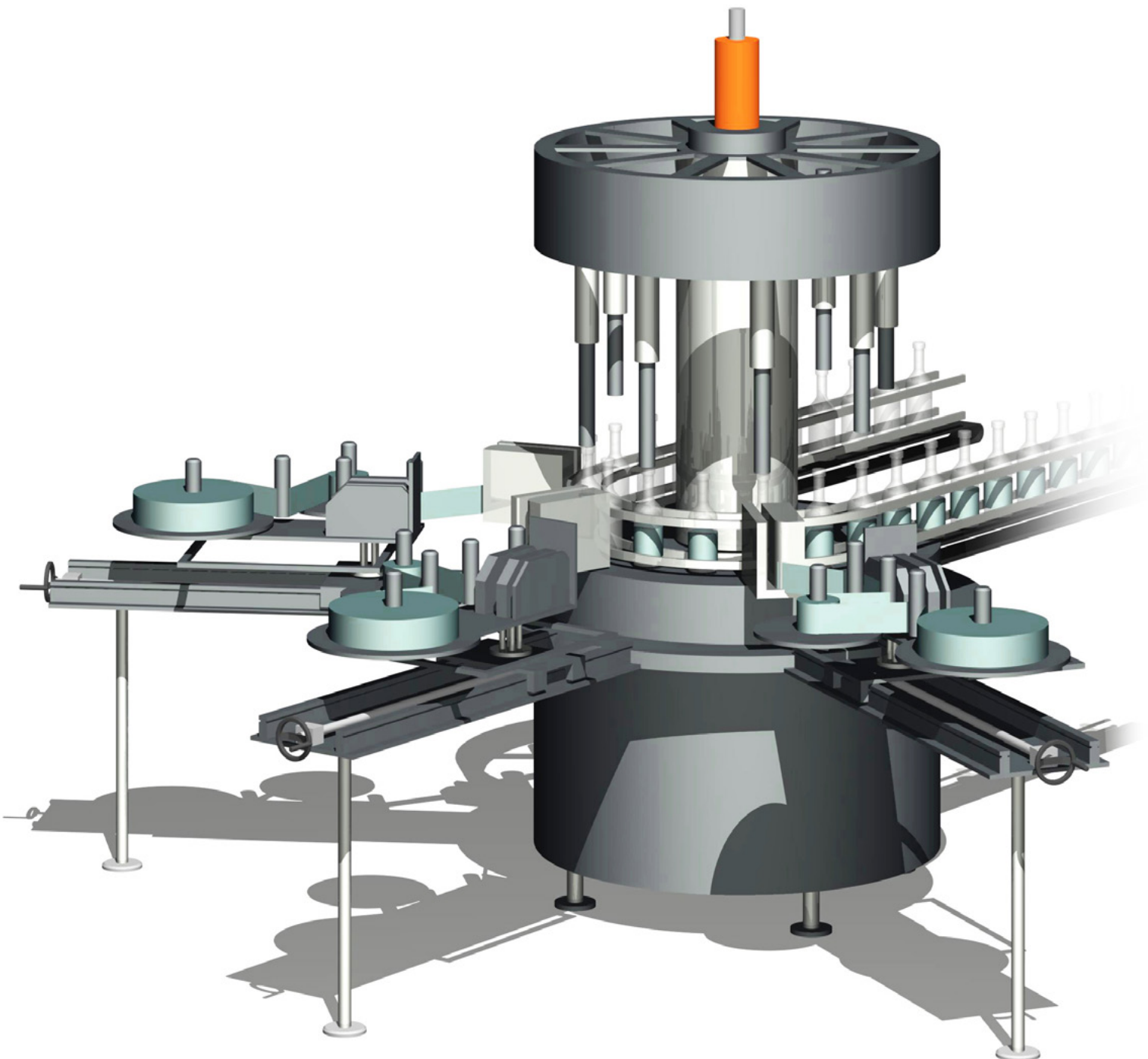



## Applications

The slip ring SR120 is used for example in industrial automation, bottling plants and labeling machines.



### Ethernet transmission: slip ring SR120

- Robust: aluminum or stainless steel housing, high IP64 protection level, high-quality seals – for reliable operation in harsh environments, no penetration of liquids
- Reliable and interference-free transmission of fieldbus, Ethernet and video signals
- Up to 20 channels (load and current), media lead-through in air or hydraulic version ensure high versatility and flexibility at the same time
- Wide variety of connector and cable connections for fast and easy installation available

### **i** Three-chamber system: Safety-Trans™ Design

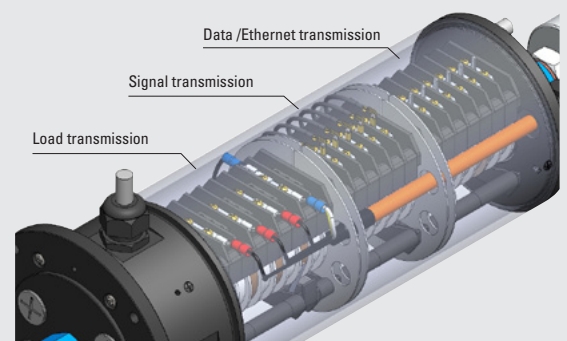

Three-chamber system to separate the load, signal and data / Ethernet transmission. Labyrinth discs increase the clearance and creepage distance to ensure electrical insulation and protect the signal contacts against contamination with abrasion dust. This extends significantly the service life and the maintenance cycles.



# Kübler slip ring technology – long-lasting and maintenance-free

The Kübler slip rings have been developed further in order to offer the customers low-maintenance up to maintenance-free slip rings with a long service life. The new innovative contact technology, using highgrade contact material, contributes significantly to this specific feature. The Safety-Trans™ design allows a safe, compact slip ring construction with combined load, signal and data/Ethernet transmission.

## Innovative contact technology

Load transmission	Signal / data transmission – Precious metal
<p>Standard pick-off spring for only load channels with copper-graphite alloy and bronze slip ring</p>	<p>Standard pick-off spring for only signal / data transmission with silver alloy and precious metal slip ring</p>
	
<ul style="list-style-type: none"> <li>· Suitable for high currents and voltages</li> <li>· Very low voltage drop</li> <li>· Very low friction coefficient</li> <li>· Long service life</li> <li>· Contact oil not required for maintenance</li> </ul>	<ul style="list-style-type: none"> <li>· Safe transmission of data and signals – especially for very low currents and voltages</li> <li>· Very low contact resistance</li> <li>· Long service life</li> <li>· Longer maintenance cycles</li> <li>· Digital and switching signals / fieldbus signals</li> <li>· Intermittent operation (constant contact resistance &lt; 0.1 ohm when stopped and when rotating)</li> <li>· Contact oil not required for maintenance</li> </ul>

## Modular construction system

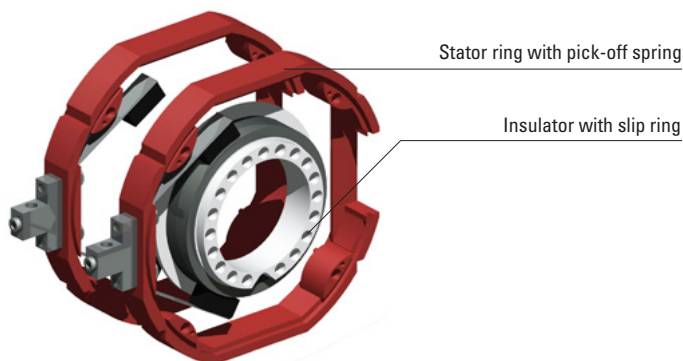



## Two-chamber system: Safety-Trans™ Design

Two-chamber system to separate the load and signal / data transmission.  
 A labyrinth seal increases the clearance and creepage distance to ensure electrical insulation and protects the signal contacts against contamination with abrasion dust. This extends significantly the service life and the maintenance cycles.

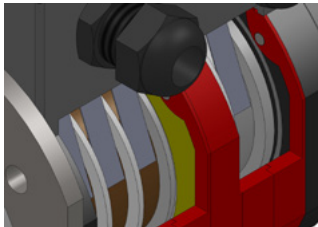

## Easy maintenance



Long maintenance cycles: only every 100 million revolutions  
 · Open the maintenance window  
 · Simply vacuum the abrasion dust  
 · Contact oil not required

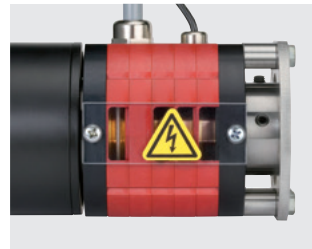

Practical maintenance window

## Three-chamber system: Safety-Trans™ Design

Three-chamber system to separate the load, signal and data / Ethernet transmission.  
 Labyrinth discs increase the clearance and creepage distance to ensure electrical insulation and protect the signal contacts against contamination with abrasion dust. This extends significantly the service life and the maintenance cycles.

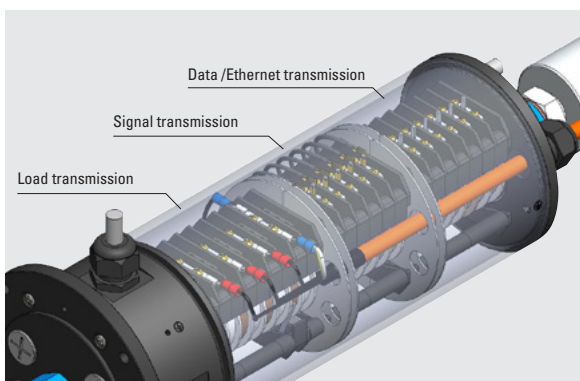

## Installation and connection

Hollow shaft mounting  
 Hollow shaft up to  $\varnothing$  30 mm

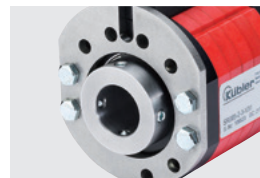

Flange mounting  
 with air lead-through



### Easily accessible connections

Terminal connections on the stator.

Rotating connection ring  
 with connecting screws.



Rotary flange with  
 connection wires.



## Kübler encoder solutions

Safe, quick, diverse and compact – qualities that make Kübler encoders ideally suited for use in packaging machines.

The sturdy bearing construction in Safety-Lock™ Design with extra strong outer bearings increases the service life and avoids downtimes and repairs.

Optical sensor technology that is resistant to magnetic fields, with a high clock speed (up to 10 MHz) guarantees optimal signal accuracy. The unique modular design of the Kübler encoders results in a wide choice of versions. The numerous connection and fixing possibilities as well as the comprehensive choice of accessories allow for flexible and universal use.

### Incremental encoders



### Miniature encoders

#### **2400 / 2420 (optical) and 2430 / 2450 (magnetic)**

- Miniature size of  $\varnothing$  24 mm
- Robust bearing design
- Resolution max. 1024 ppr
- Shaft / blind hollow shaft up to 6 mm
- Sturdy cable outlet with multiple clamping
- Protection level IP65

### Economical encoders

#### **Sendix Base KIS40 / KIH40**

- Optical
- Compact size of  $\varnothing$  40 mm
- Robust Safety-Lock™ bearing design
- Resolution max. 2500 ppr
- Short-circuit proof outputs
- Polarity protection of the supply voltage
- Protection level max. IP64



### Standard encoders

#### Sendix 5000 / 5020

- Optical
- Size of  $\varnothing$  50 mm
- Robust Safety-Lock™ bearing design
- Resolution max. 5000 ppr
- Shaft up to max. 12 mm / hollow shaft up to max. 15 mm
- Wide variety of connectors and cables
- Protection level max. IP67
- Unique variant diversity
- Order option: 24one delivery promise



### Stainless steel encoders

#### Sendix 5006 / 5026

- Optical
- Size of  $\varnothing$  50 mm
- Robust Safety-Lock™ bearing design
- Sturdy stainless steel housing (V2A)
- High-quality seals
- Stainless steel connector
- Resolution max. 5000 ppr
- Protection level max. IP67

## Encoders



## Absolute encoders



## Encoders with parallel interface

### 5852 / 5872

- Singleturn, optical
- Size of  $\varnothing$  58 mm
- Refresh rate of the position data 40 kHz
- Resolution max. 14 bit
- Shaft up to max. 10 mm / hollow shaft up to max. 12 mm
- Cable connection or connector M23
- Protection level max. IP66

## Encoders with SSI interface

### Sendix 5853 / 5873

- Singleturn, optical
- Size of  $\varnothing$  58 mm
- Robust Safety-Lock™ bearing design
- Resolution max. 17 bit
- With additional 2048 incremental or SinCos track
- BiSS interface as an option
- Shaft up to max. 10 mm / hollow shaft up to max. 15 mm
- Cable connection or connector
- Protection level max. IP67



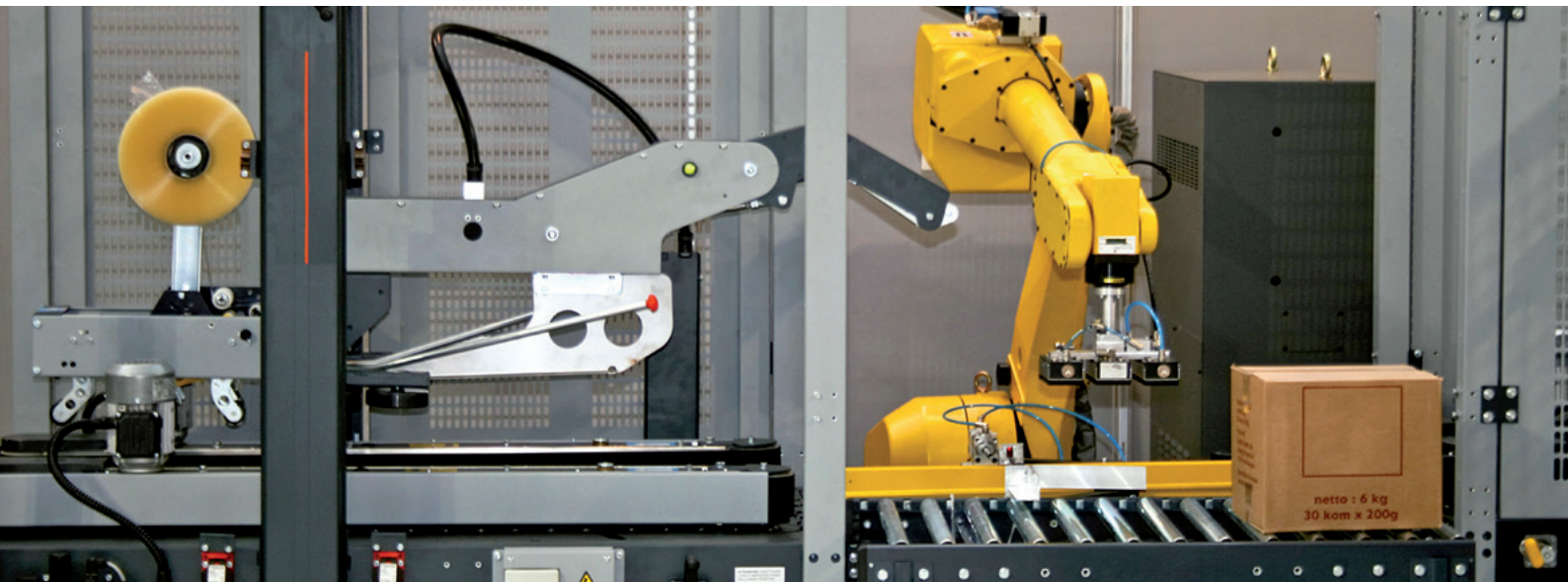

## Gearless absolute encoders

### Sendix F36 and Sendix F58

- Optical, singleturn or multiturn
- Compact size of  $\varnothing$  36 mm, size of  $\varnothing$  58 mm
- Robust Safety-Lock™ bearing design
- Intelligent-Scan-Technology™
- All singleturn and multiturn functions on one OptoASIC
- Total resolution max. 41 bit (singleturn max. 17 bit, multiturn max. 24 bit)
- Protection level max. IP67



## Fieldbus encoders

### Sendix 58xx PROFINET IO

- Optical, singleturn or multiturn
- Size  $\varnothing$  58 mm
- Robust Safety-Lock™ bearing design
- Isochronous Real-Time-Mode (IRT) – ideal for real-time applications
- Fast Start Up (FSU) – in less than one second
- Plug and Play start-up
- Media Redundancy Protocol (MRP)
- Protection level max. IP67

### Sendix F5868 / F5888 CANopen

- Optical, gearless multiturn encoders
- Intelligent-Scan-Technology™
- Size  $\varnothing$  58 mm
- Through hollow shaft up to max. 15 mm
- Robust Safety-Lock™ bearing design
- Universal Scaling Function (USF)
- Protection level max. IP67

# Encoder technologies for the packaging industry

Innovations from tradition. Kübler products benefit from 55 years experience in automation technology.

Over time they have been subject to continual development and optimized for applications in drive engineering, special purpose machinery manufacture and not least in packaging machines. Small details make a big difference. Our products feature many intelligent topquality extras and offer our customers crucial benefits. In doing so they make a significant contribution to the high availability of the plant.

## Stainless-steel encoders



Ideal for the food and beverage market. We offer a comprehensive range of stainless-steel encoders to meet the requirements of the food and beverage, dairy, pharmaceutical and chemical industries. All the external components of the encoder housing are made from stainless, austenitic nickel-chromium steel, which meets food regulation requirements. Electrical connections for the encoder are made via a high quality durable cable or connector. The high IP66 protection together with the NIRO steel ensure high levels of hygiene and safety against aggressive media.

## Robust bearings



Kübler encoders boast a very sturdy and robust bearing construction, brought together under the term Safety-Lock™. Encoders with Safety-Lock™ have positive interlocked bearings with a large bearing span and special mounting technology. This means they are able to tolerate installation errors as well as large shaft loads, as can occur as a result of temperature expansion or vibration. A further development of this technology is employed in the Sendix Heavy Duty encoders (HD-Safety-Lock™). Encoders are available for use in drive engineering that will operate reliably at speeds of up to 12,000 rpm.

## Wide temperature range



High heat resistance – combined with high rotational speeds – make the Kübler Sendix encoders the optimal solution for all applications in a high temperature environment.

## Housing geometry



The compact dimensions, the extremely compact connector solution, as well as, for example, the tangential cable outlet, permit optimal mounting in areas where installation space is tight. The through hollow shaft of the Kübler encoders leaves ample clearance for many mounting options, even behind the encoder. In order to ensure the easiest possible mounting, various mounting options are available for both solid shaft and hollow shaft variants, including, for example, clamping flanges, stator couplings and tether arms.

## Electrical interfaces



Kübler encoders boast a wide variety of interfaces. Along with incremental interfaces such as TTL / HTL and SinCos there are also absolute interfaces such as SSI and BiSS.



Absolute encoders with fieldbus interfaces such as CANopen, PROFIBUS DP, PROFINET IO, EtherCAT and Modbus are also available.



The outputs and supply voltage are short-circuit protected.

## SIL2 / SIL3 certification



Safety is – not least since the EU Machinery Directive 2006/42/EC – an “integral part of the construction of drives”.



Sendix SSI absolute encoders with additional incremental SinCos output and SinCos versions of incremental encoders are available SIL2 / SIL3 certified.

But safety goes further than this: safer components are characterized by a robust, reliable interface and by the ability to cope with high mechanical and electronic loads. On the basis of their design that has been optimized with respect to safety, Sendix encoders make an important contribution to increasing the availability of plants.

## Approvals

All encoders from the Kübler company carry the CE mark and are tested for electromagnetic compatibility and immunity to interference. As an option, our products can be UL approved.

Products with Ex approval and products certified for Functional Safety complete Kübler's products range.



## Linear measuring systems

Right there on the spot – direct detection on the running material with local control.  
The linear measuring systems from Kübler offer solutions for direct detection on the running material or conveyor belt using versatile measuring wheels or –easy-to-install magnetic band systems.





### Linear measuring systems Limes

- Incremental or absolute
- Simple to operate and mount
- Resolutions from 0.005 mm up to 1 mm
- Very high repeatability
- Magnetic non-contact measuring principle:
  - completely free of wear
  - no pitch or gear backlash errors
  - not affected by oil, dust, grease or fluids



### Length measuring system: measuring wheel + encoder

For direct detection on the running material or conveyor belt

#### Measuring wheel system

- New fixing solution for measuring wheels permits freely adjustable contact pressure
- Can be mounted in all positions
- Allows for greater distance between wheel and running material
- Measuring point can also be in the center
- Can be combined with all standard encoders (incremental, SSI, fieldbus, ...)

#### Mini-measuring wheelsystem

- With incremental interface
- Very compact (74 mm x 50 mm x 52 mm)
- Simple to install: one unit – screw on, connect, ready



## Counters and process devices

The powerful, easy-to-operate Codix preset counters act as decentralized low-cost controllers, from simple piece counting up to the control of welded seams. The compact Codix displays serve to visualize, for example, piece count, time or temperature directly at the place where these occur.





### Codix preset counters for decentralized control tasks

- Economical solution for simple control tasks without a PLC
- Local display and control – fast fault recognition during machine stoppage
- User-friendly: large, bright display, menu-driven programming via keys, versions with interface
- Can be used where hygiene is paramount: can be operated using gloves, high protection rating
- High accuracy: galvanic isolation, resistant to shock and magnetic fields, linearization up to 32 points, scaling, up to 8 digit display

#### **Application examples:**

- Mechanical stop adjustment of perforation and roller positioning
- Adhesive application
- Welded seam control

### Pulse counters, hour meters, process displays

#### **Pulse counters**

- For piece, batch and position
- Also available as dual counters

#### **Hour meters**

- For monitoring service intervals
- Tamper-proof
- With optional service preset
- Manual or electrical reset

#### **Process displays**

- For analog standard signals, temperature and strain-gauge inputs
- Very easy to program
- With galvanically isolated inputs and outputs for high measurement accuracy
- 2 relay outputs for limit value monitoring and/or optional analog output

# Tailor-made solutions – Kübler Design System

With the KDS method our customers receive a lasting solution to lowering costs, reducing the number of models available or eliminating quality deficiencies. With KDS we develop product and engineering solutions together. The method stands out because of its structured process; this delivers innovation through experience and cooperation with the customer.

*Gebhard and Lothar Kübler, Managing Directors Fritz Kübler GmbH*

## The Kübler Design System – satisfying customer demands

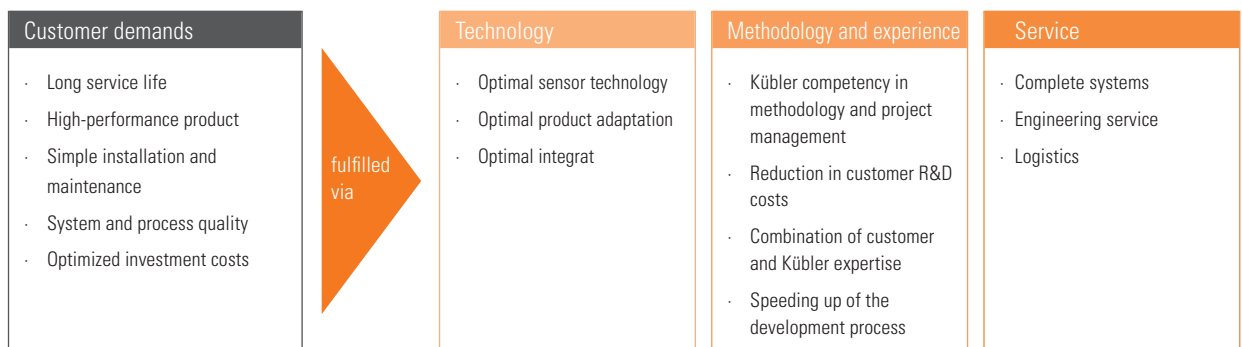

## The 4 phases of the Kübler Design System

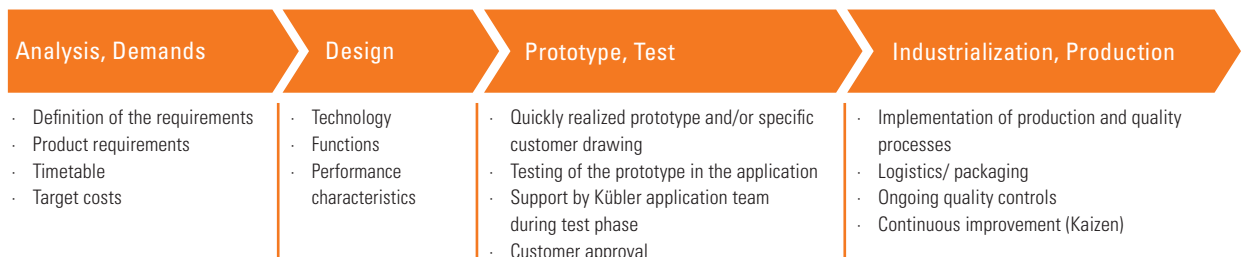

## PRESALES

- Selection tool
- Kübler website: Product Finder

Kübler industry specialists for applications and complete integration solutions – on site worldwide.



- Delivery Service 10 by 10
- 48 h Express and Repair Service

Sample Service – Fast delivery of customized versions





# Kübler Service for Planning Dependability

Fast, reliable service and professional advice have top priority at Kübler. We are globally on your doorstep in 8 service and application centers and offer our customers planning dependability. Our processes and services are certified and are constantly being improved.

## 24one 24one delivery promise

Manufacturing in 24 hours. For orders placed on working days before 9 AM, the product will be ready for dispatch on that same day. 24one is limited to 20 pieces per delivery.



## Sample Service

We manufacture samples of special designs or according to customer specification within shortest time.



## 10 by 10

We will manufacture and deliver 10 encoders within 10 working days (365 days a year - with the exception of 24th Dec. until 2nd Jan.)



## Technical Support

Kübler' applications team is present on site all over the world for advice, analysis and support.



## 48 h Express Service

We can process your order within 48 hours; we can ship stock items the same day.

Kübler Germany / Austria	+49 7720 3903 952
Kübler France	+33 3 89 53 45 45
Kübler Italy	+39 0 26 42 33 45
Kübler Poland	+48 6 18 49 99 02
Kübler Turkey	+90 216 999 9791
Kübler China	+86 10 8471 0818
Kübler India	+91 8600 147 280
Kübler USA	+1 855 583 2537



## Safety Services

- Adapted service packages
- Individual customer solutions

## AFTERSALES



Service Excellence provided by Kübler application specialists for target sectors



Service Centers, globally on your doorstep: Advice, analysis, support during installation in over 50 countries

Product security – replacement models at the end of the product life-cycle



# Product information

We offer additional information on our products and system solutions in the following main catalogs:

## Position and Motion Sensors

- Incremental and absolute encoders
- Fieldbus and Industrial Ethernet encoders
- Bearingless encoders
- Explosion protected encoders ATEX / IECEx
- Linear magnetic measuring systems
- Draw-wire encoders
- Inclinometers
- Connection technology



Order-No. German **R.100.568**  
 Order-No. English **R.100.569**

## Counters and Process Devices

- Pulse counters and preset counters
- Hour meters and timers
- Frequency meters and tachometers
- Combination time and energy meters
- Position displays
- Process displays and controllers for temperature, analog signals and strain-gauge
- Setpoint adjuster



Order-No. German **R.100.156**  
 Order-No. English **R.100.157**

## Transmission Technology

- Slip rings, modular system
- Slip rings, bearingless modular system
- Slip rings, contactless transmission
- Slip rings, compact and low-maintenance
- Slip rings, Ethernet transmission
- Optical fiber signal transmission modules
- Cables, connectors and pre-assembled cordsets



Order-No. German **R.600.948**  
 Order-No. English **R.600.948.001**

## Functional Safety

- Certified incremental and absolute encoders
- Certified explosion-protected encoders ATEX / IECEx
- Modules for safe drive monitoring
- Safe fieldbus gateways
- Safe speed monitors
- Adapted service packages
- Connection technology



Order-No. German **R65001.0001**  
 Order-No. English **R65001.0002**

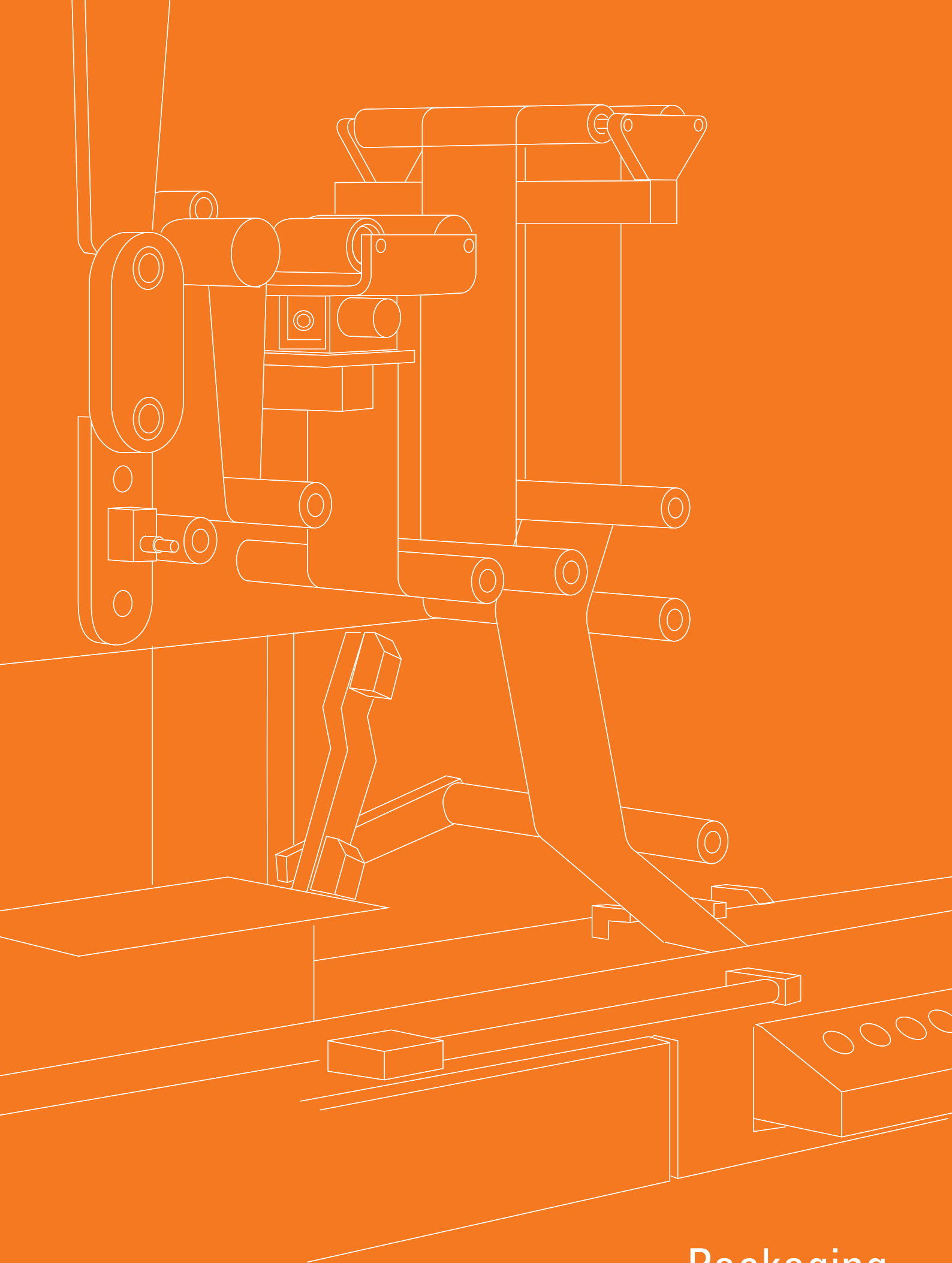

Packaging

**Kübler Group**  
**Fritz Kübler GmbH**  
Schubertstrasse 47  
78054 Villingen-Schwenningen  
Germany  
Phone +49 7720 3903-0  
Fax +49 7720 21564  
info@kuebler.com  
www.kuebler.com

[www.kuebler.com/packaging](http://www.kuebler.com/packaging)

R.100.805.001 03 250 16 ES